

成形材料試験成績表

令和5年 4月度



株式会社 未来樹脂



〒181-0013 東京都三鷹市下連雀3-38-4

三鷹産業プラザ5F

TEL:0422-70-4201 FAX:0422-43-1021

成形材料名: ポリエチレン

試験項目	試験方法	単位	規格値	試験値
密度	JIS K 7112	kg/m ³	942 以上	962
マルチフローレート	JIS K 7210	g/10min	1.5 以上 6.0 未満	5.3
引張降伏強さ	JIS K 7161	MPa	19.61 以上	27.96
デュロメータD硬さ	JIS K 7215	H _D D	60 以上	64
ヒカット軟化点	JIS K 7206	°C	105 以上	127

[備考] 本表は、材料メーカー報告および社内測定結果によるもので、当社製品の成形材料です。

K形スペーサ 試験成績書

令和 5年 4月 度



株式会社 未来樹脂



〒181-0013 東京都三鷹市下連雀 3-38-4
三鷹産業プラザ5F

TEL:0422-70-4201 FAX:0422-43-1021

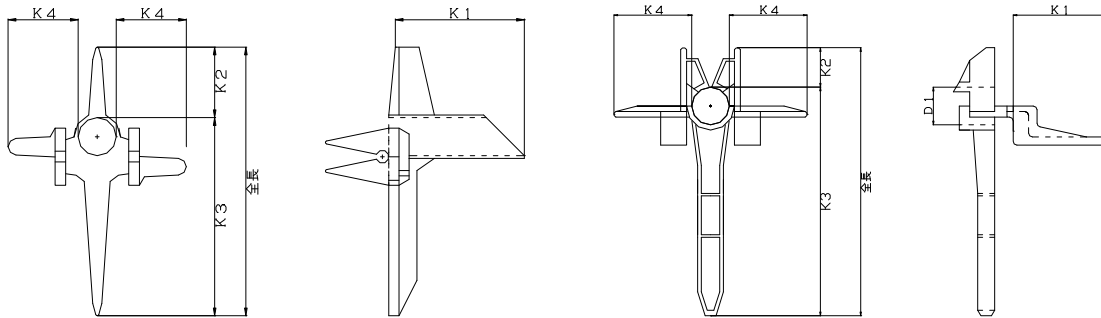

種類	項目	外観形状	K1			K2			K3			K4			全長		
			寸法	許容差	測定値	寸法	許容差	測定値	寸法	許容差	測定値	寸法	許容差	測定値	寸法	許容差	測定値
			mm	±	mm	mm	±	mm	mm	±	mm	mm	±	mm	mm	±	mm
旧K30-3-3	良	20.0	1.0	19.3	11.0	0.5	11.2	18.0	0.5	17.7	20.0	1.0	20.8	29.0	1.0	28.9	
K30-3-3	良	30.0	1.0	29.8	11.0	0.5	11.2	18.0	0.5	17.8	20.0	1.0	20.8	29.0	1.0	29.0	
旧K35-3-3	良	20.0	1.0	19.4	11.0	0.5	11.1	22.0	1.0	21.8	20.0	1.0	20.6	33.0	1.0	32.9	
K35-3-3	良	30.0	1.0	29.8	11.0	0.5	11.1	22.0	1.0	21.8	20.0	1.0	20.7	33.0	1.0	32.9	
旧K40-3-3	良	20.0	1.0	19.9	11.0	0.5	10.8	27.0	1.0	26.9	20.0	1.0	20.5	38.0	1.0	37.7	
K40-3-3	良	30.0	1.0	29.9	11.0	0.5	11.0	27.0	1.0	27.1	20.0	1.0	20.6	38.0	1.0	38.1	
K40-5-4	良	30.0	1.0	29.9	15.0	0.5	15.1	23.0	1.0	23.0	19.0	0.5	18.9	38.0	1.0	38.1	
旧K45-3-3	良	20.0	1.0	19.9	11.0	0.5	11.2	32.0	1.0	32.0	20.0	1.0	20.5	43.0	2.0	43.2	
K45-3-3	良	30.0	1.0	30.1	11.0	0.5	11.1	32.0	1.0	32.2	20.0	1.0	20.6	43.0	2.0	43.3	
K45-5-4	良	30.0	1.0	30.2	15.0	0.5	15.2	28.0	1.0	28.0	19.0	0.5	19.1	43.0	2.0	43.2	
K45-6-4	良	30.0	1.0	29.7	15.0	0.5	15.2	29.0	1.0	29.0	20.0	1.0	20.3	44.0	2.0	44.2	
旧K50-4-4	良	20.0	1.0	20.0	15.0	0.5	15.4	33.0	1.0	32.3	20.0	1.0	20.2	48.0	2.0	47.7	
K50-4-4	良	30.0	1.0	29.8	15.0	0.5	15.5	33.0	1.0	32.4	20.0	1.0	20.4	48.0	2.0	47.9	
K50-5-4	良	30.0	1.0	29.8	15.0	0.5	15.2	33.0	1.0	32.9	19.0	0.5	18.9	48.0	2.0	48.1	
K50-6-4	良	30.0	1.0	30.0	15.0	0.5	15.0	33.0	1.0	33.5	20.0	1.0	20.2	48.0	2.0	48.5	
K50-6-6S	良	16.0	0.5	15.5	12.0	0.5	11.8	35.0	1.0	35.9	17.0	0.5	16.6	47.0	2.0	47.7	
旧K55-5-4	良	20.0	1.0	19.2	15.0	0.5	14.6	37.0	1.0	37.0	20.0	1.0	20.4	52.0	2.0	51.6	
K55-5-4	良	30.0	1.0	30.0	15.0	0.5	15.3	37.0	1.0	37.3	20.0	1.0	20.8	52.0	2.0	52.6	
K55-6-4	良	30.0	1.0	29.7	15.0	0.5	15.0	38.0	1.0	38.0	20.0	1.0	20.2	53.0	2.0	53.0	
K60-6-4	良	30.0	1.0	30.0	15.0	0.5	15.4	43.0	2.0	43.3	20.0	1.0	20.3	58.0	2.0	58.7	
K60-6-6JR	良	30.0	1.0	29.5	17.0	0.5	16.9	41.0	2.0	40.6	29.0	1.0	28.3	58.0	2.0	57.5	
K60-6-6S	良	17.0	0.5	17.2	11.0	0.5	11.4	45.0	2.0	43.9	17.0	0.5	16.7	56.0	2.0	55.3	
K65-6-4	良	30.0	1.0	30.0	15.0	0.5	15.3	48.0	2.0	48.1	20.0	1.0	20.1	63.0	2.5	63.4	
K70-6-6	良	30.0	1.0	29.7	15.0	0.5	15.0	53.0	2.0	53.5	20.0	1.0	19.9	68.0	2.5	68.5	
K70-6-6P	良	25.0	1.0	24.8	16.0	0.5	16.2	51.0	2.0	50.7	27.0	1.0	26.7	67.0	2.5	66.9	
K70-10-10	良	18.0	0.5	18.0	9.0	0.5	9.1	58.0	2.0	57.7	22.0	1.0	21.9	67.0	2.5	66.8	
K74-6-6L	良	30.0	1.0	30.7	6.0	0.5	6.4	59.0	2.0	59.7	20.0	1.0	19.5	65.0	2.5	66.1	
K80-4-4L	良	30.0	1.0	30.0	6.0	0.5	6.5	57.0	2.0	57.1	22.0	1.0	21.5	63.0	2.5	63.6	
K80-6-6	良	30.0	1.0	29.0	15.0	0.5	15.0	63.0	2.5	64.1	20.0	1.0	20.0	78.0	2.5	79.1	
K80-6-6L	良	30.0	1.0	30.8	6.0	0.5	6.5	65.0	2.5	66.1	20.0	1.0	19.8	71.0	2.5	72.6	
旧K80-10-6	良	20.0	1.0	20.2	8.0	0.5	8.4	69.0	2.5	69.0	10.0	0.5	9.5	77.0	2.5	77.4	

項目 種類	外観形状	K1			K2			K3			K4			全長		
		寸法	許容差	測定値	寸法	許容差	測定値	寸法	許容差	測定値	寸法	許容差	測定値	寸法	許容差	測定値
		mm	±	mm	mm	±	mm	mm	±	mm	mm	±	mm	mm	±	mm
K80-10-6	良	30.0	1.0	30.5	16.0	0.5	15.6	62.0	2.5	62.8	30.0	1.0	30.2	78.0	2.5	78.4
K80-10-10	良	18.0	0.5	18.1	9.0	0.5	9.0	68.0	2.5	67.7	22.0	1.0	22.0	77.0	2.5	76.7
K85-4-4L	良	30.0	1.0	30.2	6.0	0.5	6.4	64.0	2.5	64.1	22.0	1.0	21.9	70.0	2.5	70.5
旧K85-10-6	良	20.0	1.0	19.9	10.0	0.5	10.2	73.0	2.5	72.3	10.0	0.5	9.5	83.0	2.5	82.5
K85-10-6	良	30.0	1.0	29.9	16.0	0.5	16.0	67.0	2.5	67.7	30.0	1.0	30.2	83.0	2.5	83.7
K90-4-4L	良	30.0	1.0	30.0	6.0	0.5	6.5	69.0	2.5	69.2	22.0	1.0	22.0	75.0	2.5	75.7
K90-4-4S	良	30.0	1.0	29.7	33.0	1.0	32.6	55.0	2.0	55.7	27.0	1.0	26.8	88.0	2.5	88.3
K90-6-4	良	30.0	1.0	30.2	15.0	0.5	14.6	70.0	2.5	70.7	23.0	1.0	23.0	85.0	2.5	85.3
K90-10-6H	良	30.0	1.0	30.5	16.0	0.5	15.5	69.0	2.5	69.8	30.0	1.0	30.1	85.0	2.5	85.3
K90-10-6	良	20.0	1.0	19.1	15.0	0.5	15.4	70.0	2.5	70.8	23.0	1.0	23.6	85.0	2.5	86.2
K90-10-6L	良	30.0	1.0	29.2	15.0	0.5	15.4	70.0	2.5	70.9	23.0	1.0	23.4	85.0	2.5	86.3
K95-4-4S	良	30.0	1.0	29.7	33.0	1.0	32.4	60.0	2.5	59.9	27.0	1.0	26.7	93.0	3.0	92.3
K95-6-6L	良	30.0	1.0	30.7	6.0	0.5	6.4	75.0	2.5	75.5	20.0	1.0	19.6	81.0	2.5	81.9
K95-6-6S	良	30.0	1.0	29.9	17.0	0.5	16.7	76.0	2.5	75.7	29.0	1.0	28.4	93.0	3.0	92.4
K95-10-6	良	30.0	1.0	29.9	20.0	1.0	19.2	70.0	2.5	70.8	23.0	1.0	22.5	90.0	3.0	90.0
K95-10-6H	良	30.0	1.0	30.4	16.0	0.5	15.6	74.0	2.5	75.3	30.0	1.0	30.0	90.0	3.0	90.9
K95-10-10	良	30.0	1.0	30.4	20.0	1.0	20.5	70.0	2.5	69.9	25.0	1.0	24.4	90.0	3.0	90.4
K95-13-6	良	22.0	1.0	21.9	20.0	1.0	20.0	70.0	2.5	71.2	23.0	1.0	23.3	90.0	3.0	91.2
K95-13-6L	良	30.0	1.0	29.8	20.0	1.0	20.0	70.0	2.5	70.1	23.0	1.0	23.0	90.0	3.0	90.1
K95-13-13	良	30.0	1.0	30.4	18.0	0.5	18.5	72.0	2.5	71.3	23.0	1.0	23.0	90.0	3.0	89.8
K100-10-6H	良	30.0	1.0	30.4	16.0	0.5	15.5	79.0	2.5	78.9	30.0	1.0	30.0	95.0	3.0	94.4
K100-10-6P	良	25.0	1.0	25.0	15.0	0.5	15.5	81.0	2.5	80.7	25.0	1.0	24.6	96.0	3.0	96.2
K100-10-10	良	30.0	1.0	29.9	19.0	0.5	18.5	76.0	2.5	76.9	24.0	1.0	23.8	95.0	3.0	95.4
K100-13-10	良	22.5	1.0	22.2	15.0	0.5	14.9	75.0	2.5	76.2	41.5	2.0	41.7	90.0	3.0	91.1
K100-13-13	良	22.0	1.0	21.7	15.0	0.5	15.5	80.0	2.5	79.1	23.0	1.0	22.6	95.0	3.0	94.6
K105-6-6H	良	25.0	1.0	24.6	17.0	0.5	16.5	83.0	2.5	83.3	26.0	1.0	26.3	100.0	3.0	99.8
K110-4-4S	良	30.0	1.0	29.6	43.0	2.0	42.6	65.0	2.5	64.1	27.0	1.0	26.9	108.0	3.0	106.7
K110-6-6H	良	25.0	1.0	24.7	17.0	0.5	16.5	88.0	2.5	88.0	27.0	1.0	26.4	105.0	3.0	104.5
K110-10-6	良	30.0	1.0	29.6	20.0	1.0	19.9	85.0	2.5	84.5	23.0	1.0	22.7	105.0	3.0	104.4
K110-10-6H	良	30.0	1.0	30.9	16.0	0.5	15.6	89.0	2.5	89.0	30.0	1.0	29.9	105.0	3.0	104.6
K110-10-10	良	30.0	1.0	30.7	20.0	1.0	19.7	82.0	2.5	81.3	24.0	1.0	24.3	102.0	3.0	101.0
K110-13-6	良	22.0	1.0	21.7	20.0	1.0	20.0	85.0	2.5	85.0	23.0	1.0	23.2	105.0	3.0	105.0
K110-13-6L	良	30.0	1.0	30.1	20.0	1.0	20.4	85.0	2.5	84.2	23.0	1.0	23.2	105.0	3.0	104.6
K110-13-13	良	30.0	1.0	30.4	20.0	1.0	20.1	84.0	2.5	84.0	23.0	1.0	23.2	104.0	3.0	104.1
K115-6-6H	良	25.0	1.0	24.6	17.0	0.5	16.6	93.0	3.0	92.6	27.0	1.0	26.3	110.0	3.0	109.2
K120-6-6H	良	25.0	1.0	24.8	17.0	0.5	16.6	98.0	3.0	98.0	27.0	1.0	26.2	115.0	3.0	114.6
K120-10-6H	良	30.0	1.0	30.6	16.0	0.5	15.6	99.0	3.0	99.1	30.0	1.0	30.1	115.0	3.0	114.7
K120-10-10	良	30.0	1.0	30.0	20.0	1.0	20.6	95.0	3.0	94.6	24.0	1.0	24.3	115.0	3.0	115.2
K120-13-10	良	22.5	1.0	23.0	15.0	0.5	15.0	95.0	3.0	95.4	41.5	2.0	41.5	110.0	3.0	110.4
K120-13-13	良	30.0	1.0	30.0	20.0	1.0	20.2	95.0	3.0	95.4	23.0	1.0	23.4	115.0	3.0	115.6
K125-4-4S	良	30.0	1.0	29.7	48.0	2.0	47.2	75.0	2.5	75.4	27.0	1.0	27.0	123.0	3.0	122.6
K125-10-6	良	30.0	1.0	29.7	20.0	1.0	20.1	100.0	3.0	100.5	23.0	1.0	22.4	120.0	3.0	120.6
K125-13-6	良	22.0	1.0	21.9	20.0	1.0	20.4	100.0	3.0	98.9	23.0	1.0	23.4	120.0	3.0	119.3
K125-13-6L	良	30.0	1.0	30.0	20.0	1.0	19.6	100.0	3.0	99.4	23.0	1.0	23.2	120.0	3.0	119.0
K130-10-10	良	30.0	1.0	30.0	20.0	1.0	20.3	105.0	3.0	104.6	25.0	1.0	24.7	125.0	3.0	124.9
K130-13-10	良	22.5	1.0	22.9	15.0	0.5	14.7	105.0	3.0	106.6	41.5	2.0	41.4	120.0	3.0	121.3
K130-13-13	良	30.0	1.0	30.5	20.0	1.0	19.7	105.0	3.0	105.3	23.0	1.0	23.4	125.0	3.0	125.0
K135-10-6H	良	30.0	1.0	29.6	16.0	0.5	15.8	114.0	3.0	113.7	30.0	1.0	29.5	130.0	3.0	129.5
K145-10-6H	良	30.0	1.0	30.1	16.0	0.5	16.0	124.0	3.0	123.3	30.0	1.0	29.7	140.0	3.0	139.3
K150-10-10	良	30.0	1.0	30.2	20.0	1.0	20.1	125.0	3.0	123.5	25.0	1.0	24.7	145.0	3.0	143.6
K150-13-10	良	22.5	1.0	22.6	15.0	0.5	14.8	125.0	3.0	125.2	41.5	2.0	41.6	140.0	3.0	140.0
K150-13-13	良	30.0	1.0	30.5	20.0	1.0	20.3	125.0	3.0	124.4	23.0	1.0	23.0	145.0	3.0	144.7